

Piping. Systems. Solutions.

FOR OVER 80 YEARS

Fire Protection Solutions



Piping. Systems. Solutions.

FOR OVER 80 YEARS



Victaulic[®]

The logo features a stylized checkmark symbol to the left of the word "Victaulic" in a bold, sans-serif font. A horizontal orange line is positioned below the text.

Victaulic Vortex

- **What a hybrid system is:**

- Patented supersonic emitter creates a multi-layer shock wave of nitrogen which atomizes the water to a sub 10 micron level. Then it:
- Creates a *homogenous* suspension of nitrogen gas and water by imbedding the water molecules into the nitrogen molecules

- FM 5580 Approval Machine Spaces/Turbine Enclosure
- UL2127 Test Report by UL and FM for Class A and B fires
- NFPA 770 Approval
- Request for new standard under review by VDS

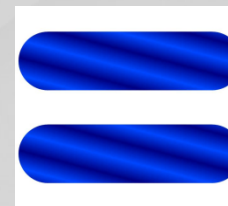
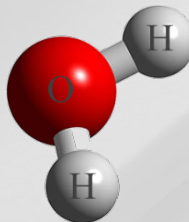
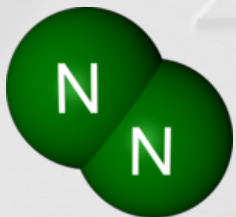

Victaulic Vortex

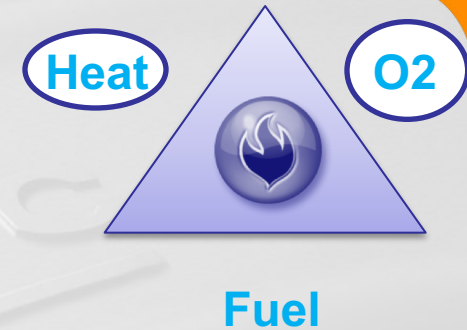

- **How does it work?**

- Nozzles deliver hybrid media consisting of nitrogen and water as very fine droplets
- Hybrid media extinguishes fires by:
 - Cooling the flame, fire plume, fuel
 - Oxygen displacement by water vapor O2 level below 16%
 - Attenuate Radiant heat Transfer
- No Room Integrity Needed & No Pumps Needed

Victaulic Vortex

- Fire Extinguishing Mechanics

Oxygen Concentration Levels and Effects

22
20
18
16
14
12
10
8
6
4
2
0

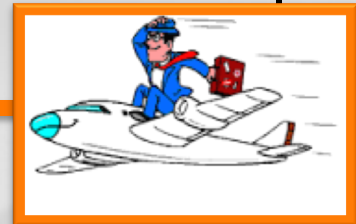
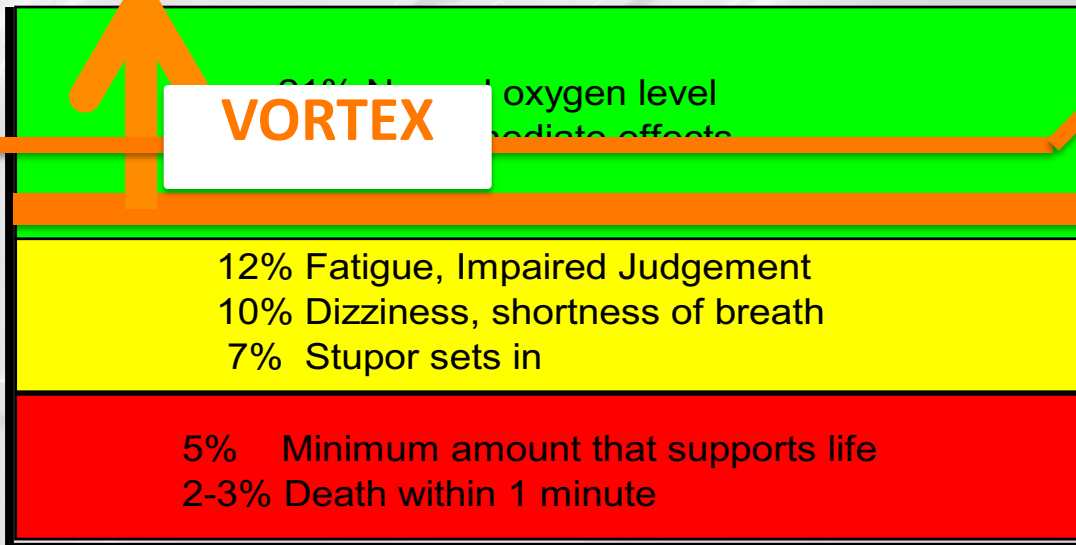

O₂ @ 12%, exit < 5 min.

O₂ @ 10%, exit < 3 min.

O₂ @ 8%, exit < 30 sec.

Victaulic Vortex

- **Operational / Design Overview**
 - Homogeneous Suspension
 - **Created using**
 - Nitrogen pressure is reduced at emitter to **1.72 bar**
 - Water pressure is reduced to only **0.35 bar** at emitter



Victaulic Vortex

- **Emitter details**

- Brass, Stainless steel or PVDF
- 1/8", 1/2" or 5/8" opening for nitrogen flow

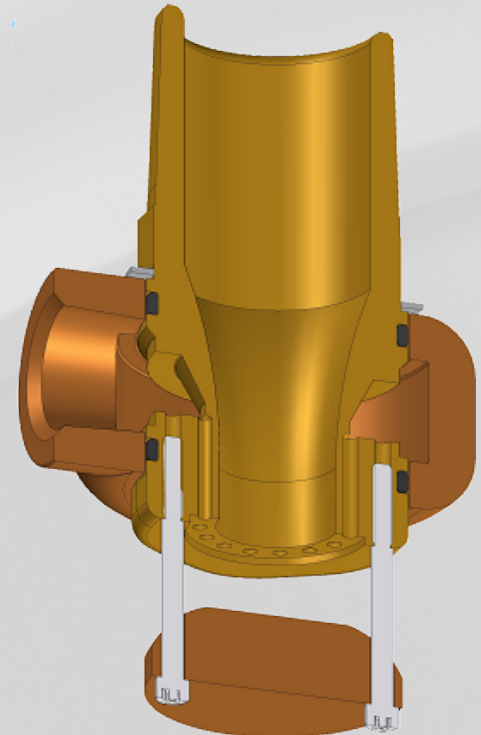
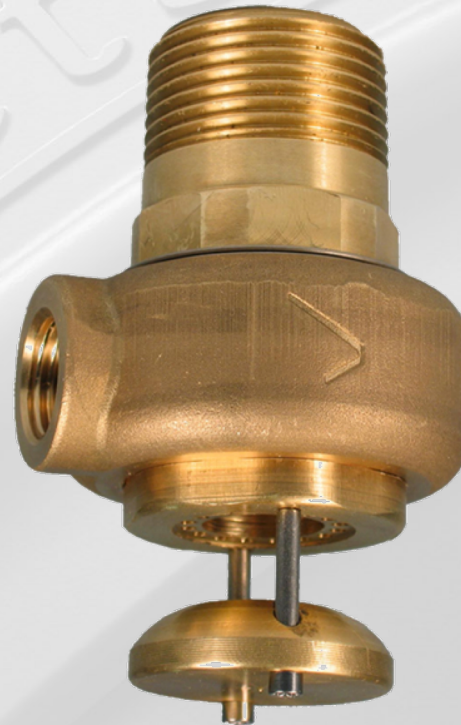
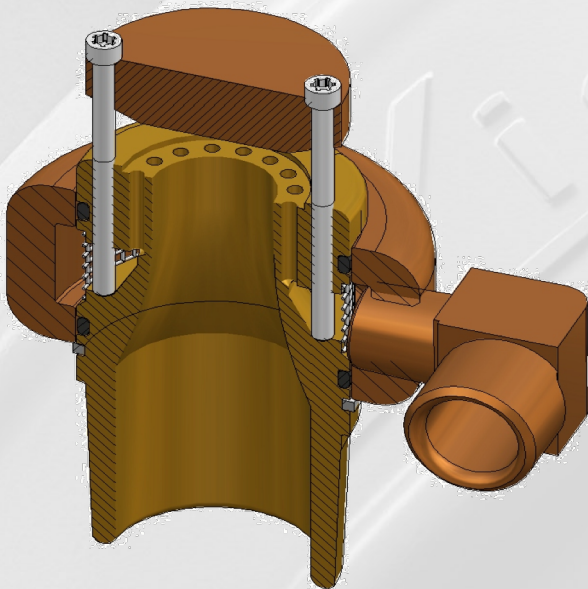

Victaulic Vortex

- Installation Overview:
MULTI ZONE

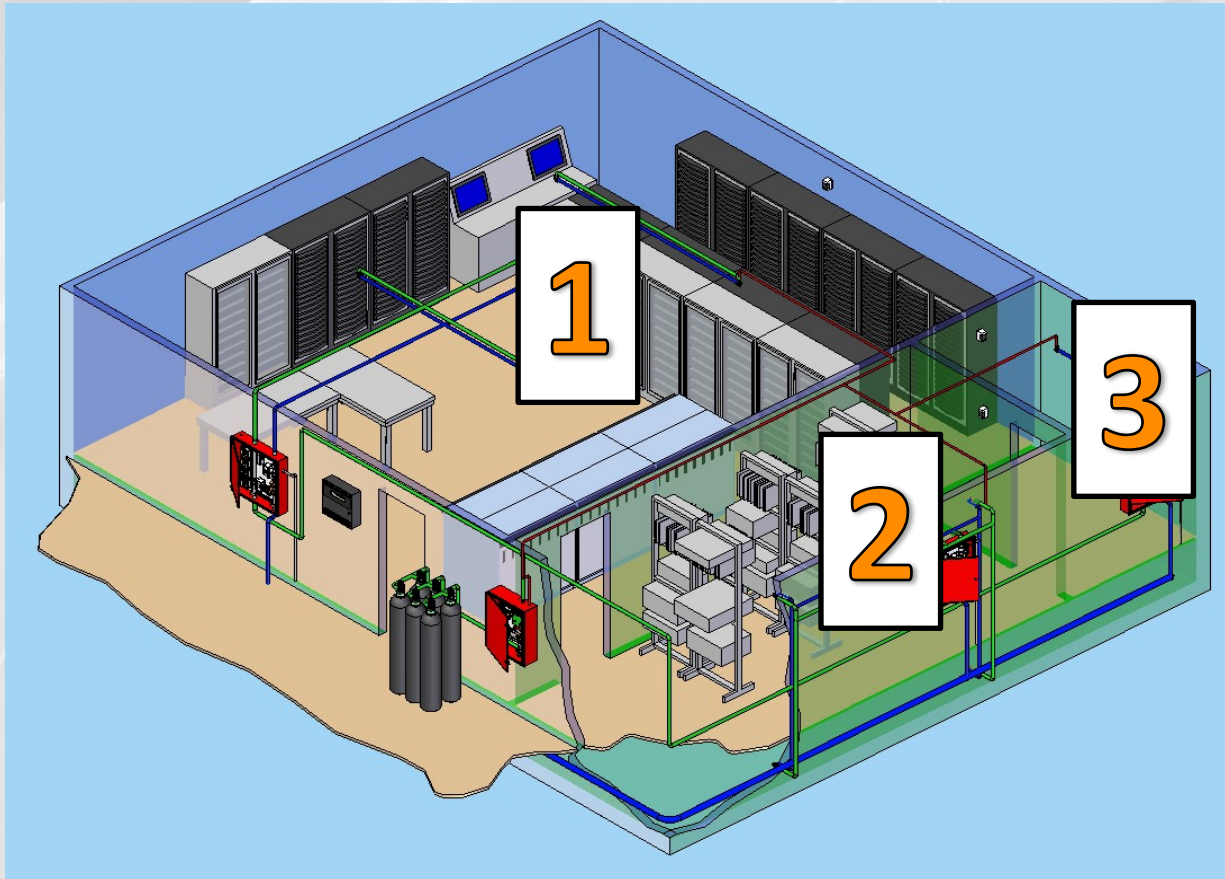

Victaulic Vortex

- Installation Overview:
SINGLE ZONE

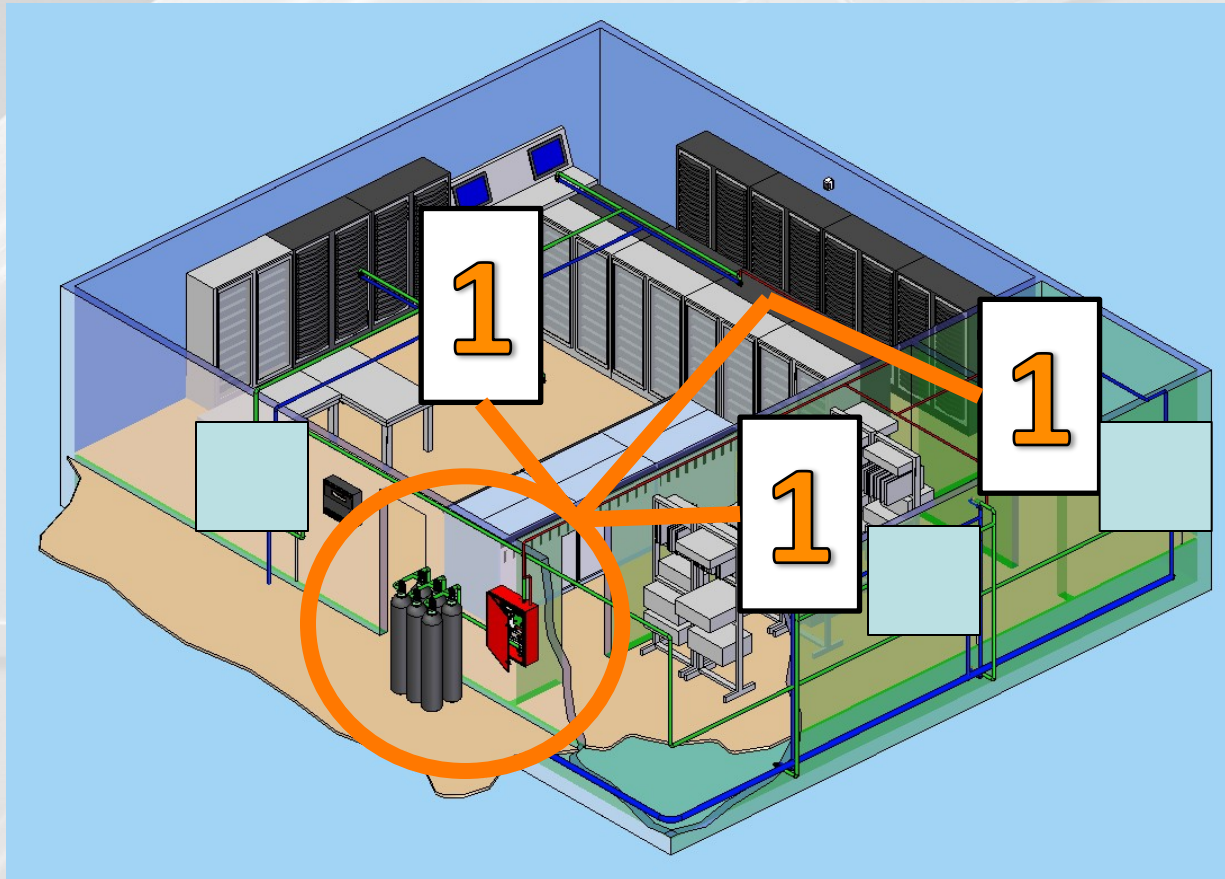



Piping. Systems. Solutions.

FOR OVER 80 YEARS

Corrosion





Important Change to NFPA-13 for Air Compressors in Dry and Pre-Action Systems



8.2.7.5.2 Compressed Air (NEW)

Where an air compressor is dedicated for the sprinkler system, the air compressor shall be listed for fire protection.

2025 edition

NFPA
13

Standard for the
Installation of
Sprinkler Systems

Nitrogen Generator



Air

98% Nitrogen



20 Månader

Remember:

- 95% or less Purity Nitrogen: Completely Ineffective for Fire Sprinkler application
- 98% Purity Nitrogen: Effective, but difficult to maintain long term



VAPOR

Pipe Shield

Vapor Phase Corrosion Inhibitor (VpCI®) Delivery System

The next innovation in corrosion prevention technology for dry & pre-action fire sprinkler systems



Piping. Systems. Solutions.



FOR OVER 80 YEARS





Compressed Air with Vapor Pipe Shield

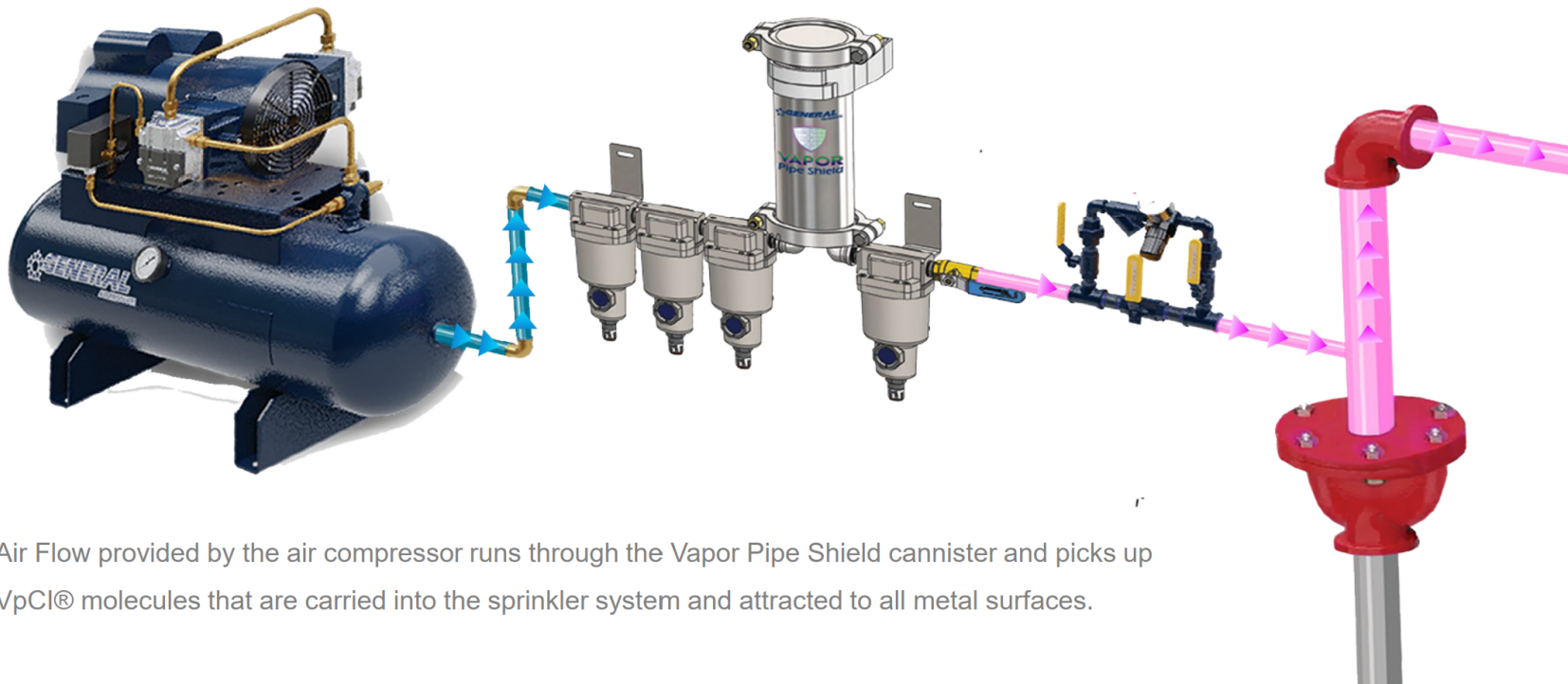

Air Flow provided by the air compressor runs through the Vapor Pipe Shield canister and picks up VpCl® molecules that are carried into the sprinkler system and attracted to all metal surfaces.

VPS Vapor Shield UL Approval

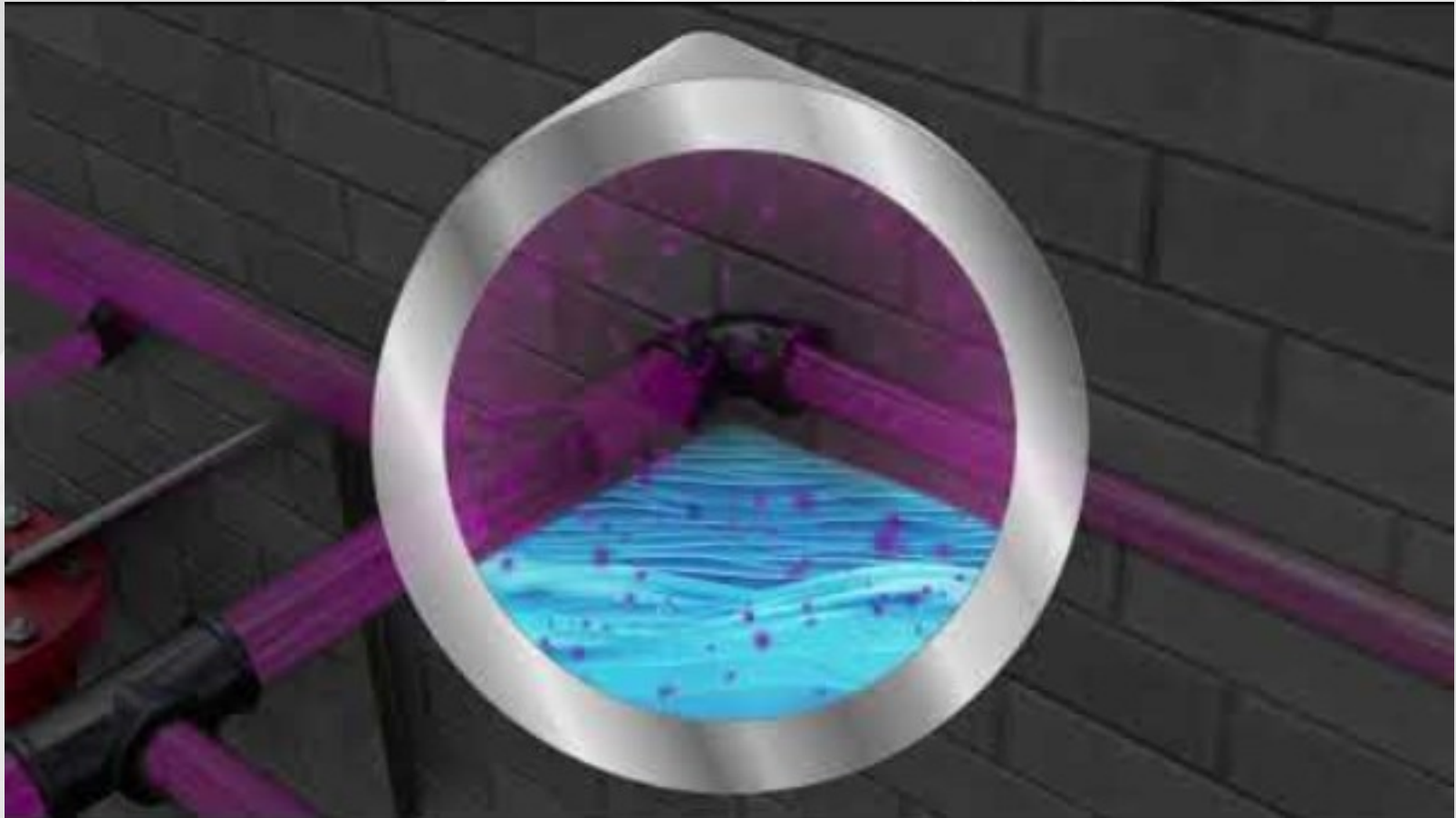



Vapor Phase Corrosion Inhibitor (VpCI®) Delivery System

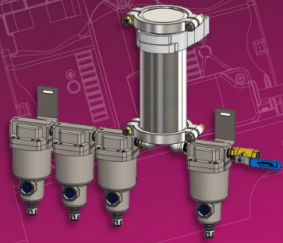

VPS-500

(20" x 22" x 6.5")

Up to 500 Gallon Fill Capacity

Up to 2,000 Gallon Total Capacity

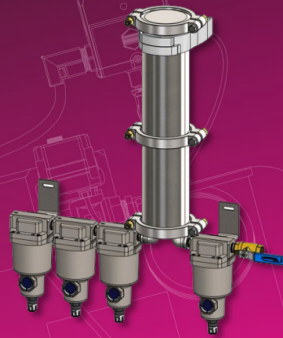

VPS-1000

(28" x 22" x 6.5")

Up to 1,000 Gallon Fill Capacity

Up to 4,000 Gallon Total Capacity

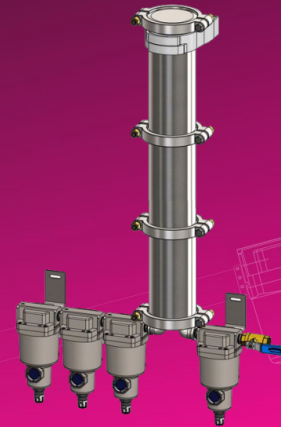

VPS-1500

(36" x 22" x 6.5")

Up to 1,500 Gallon Fill Capacity

Up to 6,000 Gallon Total Capacity

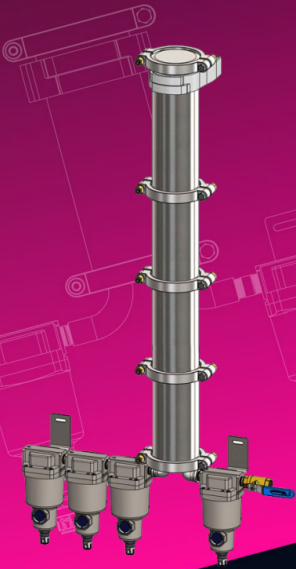

VPS-2000

(42" x 22" x 6.5")

Up to 2,000 Gallon Fill Capacity

Up to 8,000 Gallon Total Capacity

Compressed Air with Vapor Pipe Shield

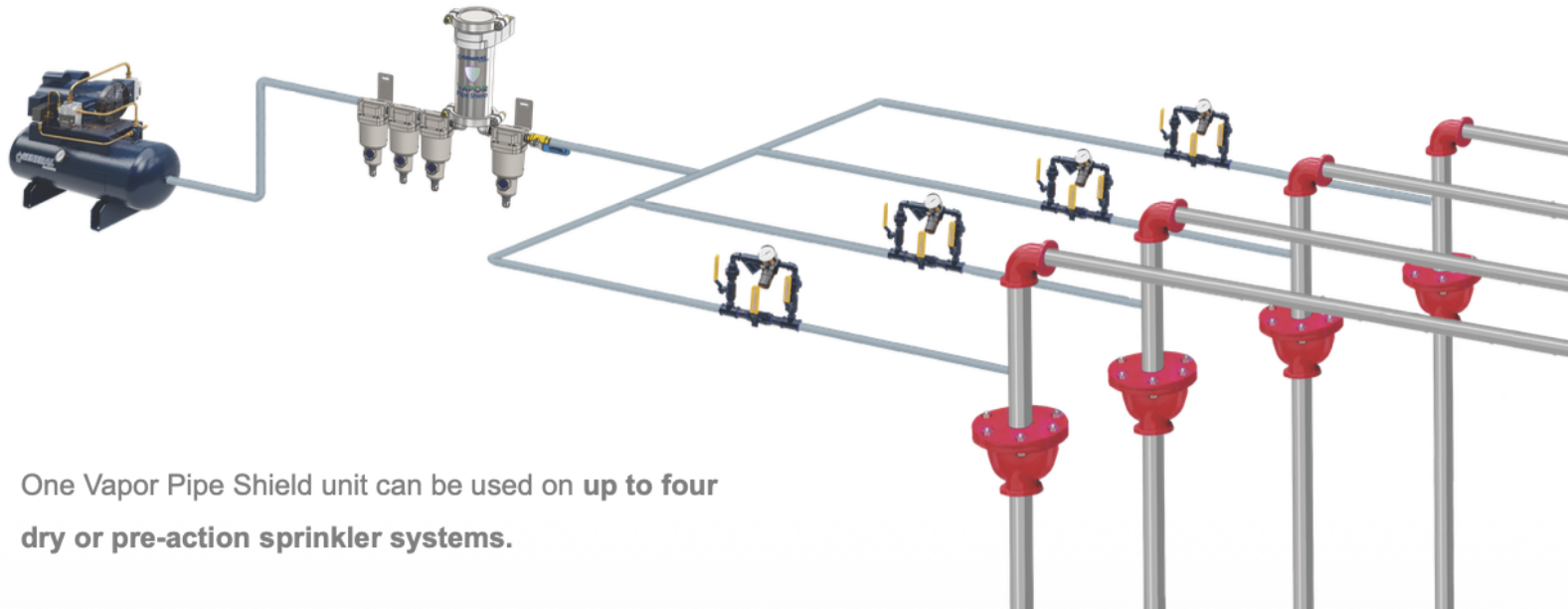

One Vapor Pipe Shield unit can be used on **up to four** dry or pre-action sprinkler systems.

Vapor Phase Corrosion Inhibitor (VpCI®) Delivery System



Compressed Air with Vapor Pipe Shield

VpCI Effectiveness Demonstration on Partially Submerged Bare Carbon Steel

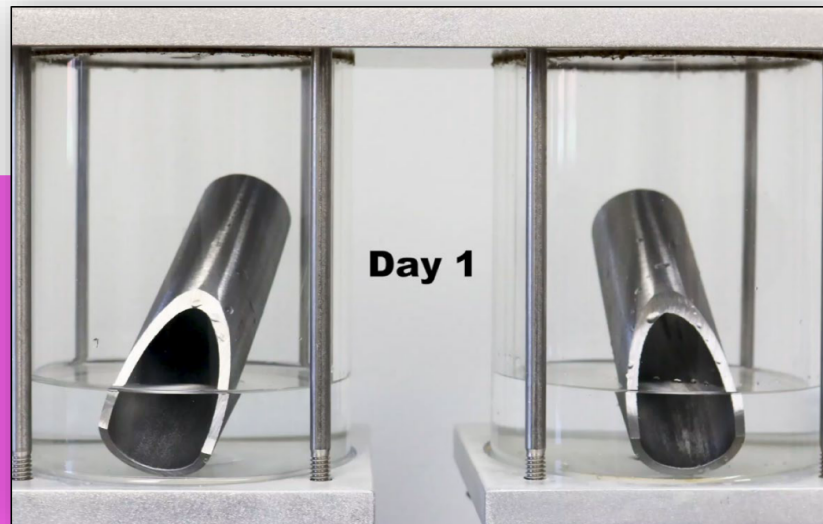

Standard
Compressed Air

Vapor Phase Corrosion Inhibitor (VpCI®) Delivery System



Compressed Air with Vapor Pipe Shield

VpCI Effectiveness Demonstration on Partially Submerged Bare Carbon Steel



5 Years Later...

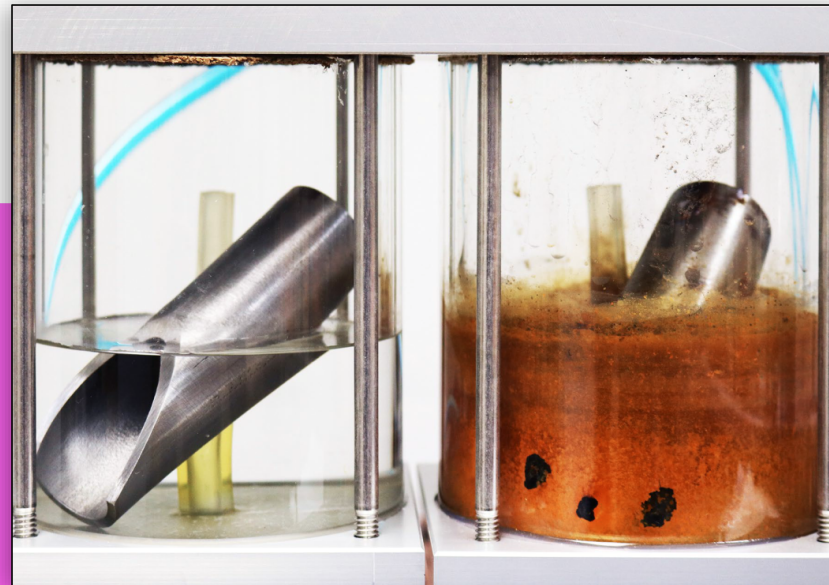

Standard
Compressed Air

Vapor Phase Corrosion Inhibitor (VpCI®) Delivery System



Compressed Air with Vapor Pipe Shield

VpCI Effectiveness Demonstration on Partially Submerged Bare Carbon Steel



5 Years Later...



Standard
Compressed Air

Vapor Phase Corrosion Inhibitor (VpCI®) Delivery System



Compressed Air with Vapor Pipe Shield

VpCI Effectiveness Demonstration on Partially Submerged Galvanized Steel



Submerged
5 Years



Corrosion Efficacy Testing: Compressed Air vs. N2 vs. VCI

IMPORTANT NOTE: coupon or “mil loss” testing assumes 98% pure nitrogen is maintained for the entirety of the test.

In the field, if your nitrogen generator is running below 98%, you are likely experiencing significant corrosion in the piping system. If the system indicates 95% or less pure nitrogen, you are not realizing any notable corrosion protection.

***When was the last time you checked purity levels?
Where did you check your system?***



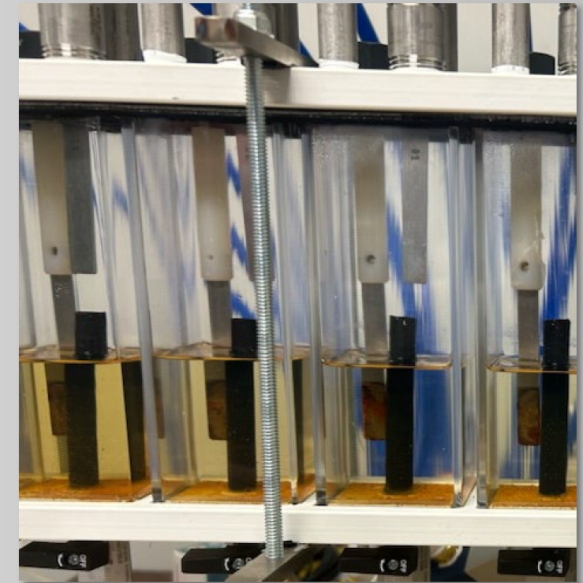
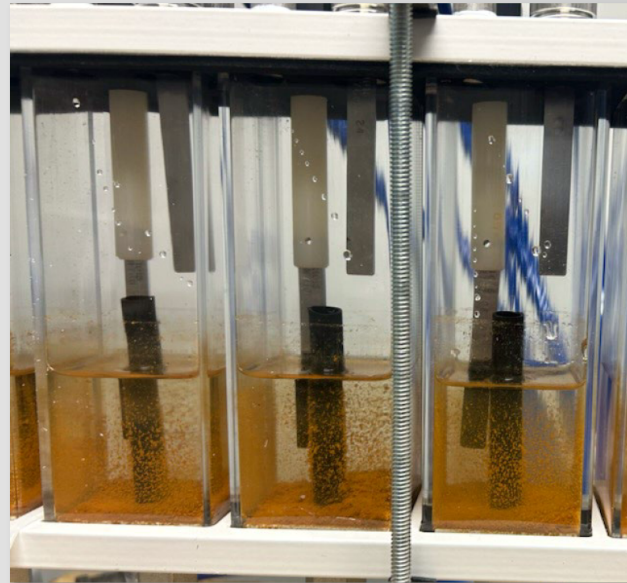
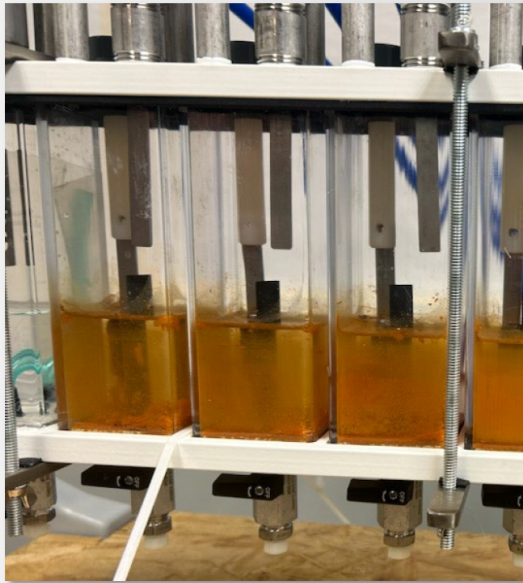

Which one is which?

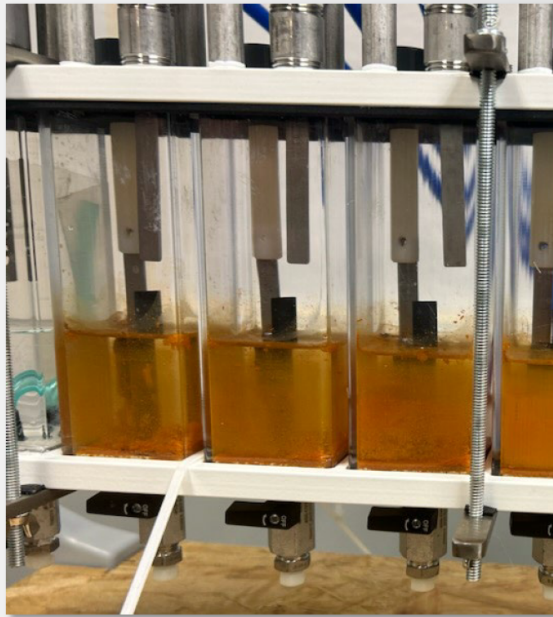

Compressed Air

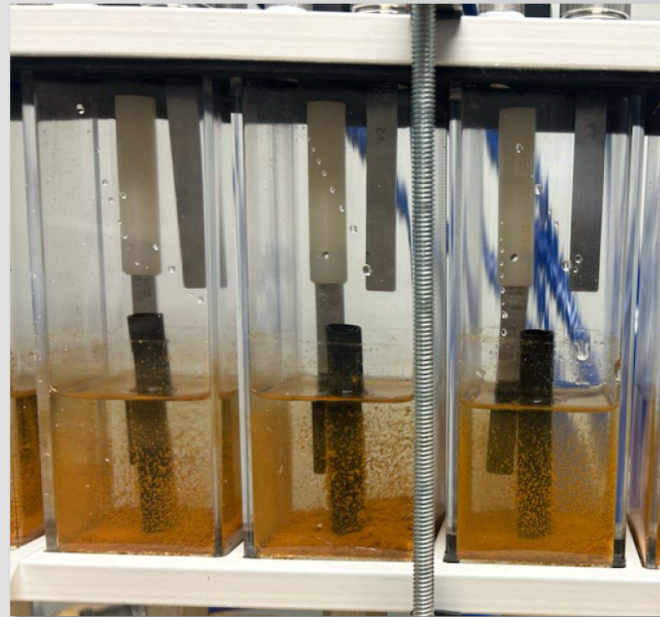

98% Purity Nitrogen

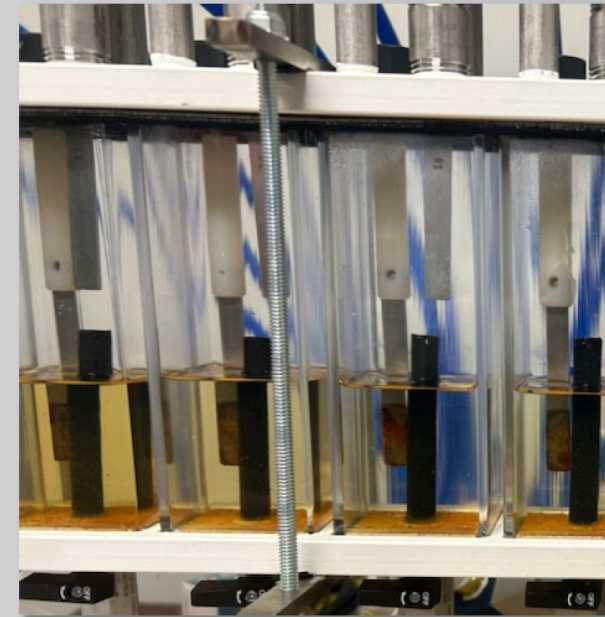

Vapor Corrosion Inhibitor

Amount of Corrosion Over Time

Vapor Corrosion Inhibitor	
Date of Test	Estimated Total Mills Lost
6 months	0.08
12 months	0.16
18 months	0.17

98% Purity Nitrogen	
Date of Test	Estimated Total Mills Lost
6 months	0.4
12 months	1.1
18 months	2.5

Compressed Air	
Date of Test	Estimated Total Mills Lost
6 months	3.15
12 months	5.53
18 months	19.95

How long will my pipe last when protected with Vapor Pipe Shield?

As long as you continue to change the replacement cartridge annually.

Annual cartridge replacement is vital for the success of mitigating corrosion with Vapor Pipe Shield.

You should replace the cartridge each year. Each year that you do, your corrosion mitigation will last another year.





Register your unit on day 1.





Meet the **Digital Maintenance Timer**

The Digital Maintenance Timer (DMT-1) acts as a notifying device for required annual maintenance on **select fire protection air supply equipment, including Vapor Pipe Shield.**

-  Set it and forget it — it reminds you at just the right time. Alerts include: buzzer, red LED, and alarm contact terminal.
-  Activates after 11 months of use.
-  Battery powered — no external power needed.
-  [Quick QR Code](#) to order the proper Maintenance Kit.



Maintenance Kits



VPS-500 Annual Maintenance Kit



VPS-2000 Annual Maintenance Kit

**System Installation & Maintenance videos are available on generalairproducts.com.*

Vapor Corrosion Inhibitor Testing: What did we learn?

To purge, or not to purge?

Because VpCI® is physically attracted to metal, it will naturally migrate on its own, even without air flow.

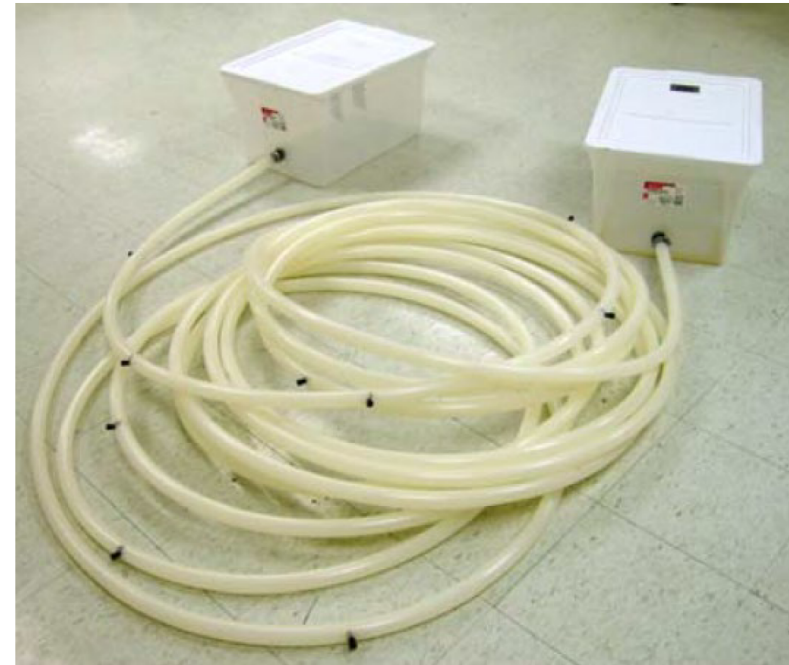



Does VpCI work on existing (NFPA 25) systems?

Absolutely, yes.

Sprinkler system piping will always last longer with the inclusion of VpCI than without it.

Further, the Vapor Pipe Shield UL 2901B Listing includes all NFPA 13 and NFPA 25 applications.

There is more to understand about existing sprinkler systems and the amount of corrosion that has taken place!



Does VpCI work where there is standing water?

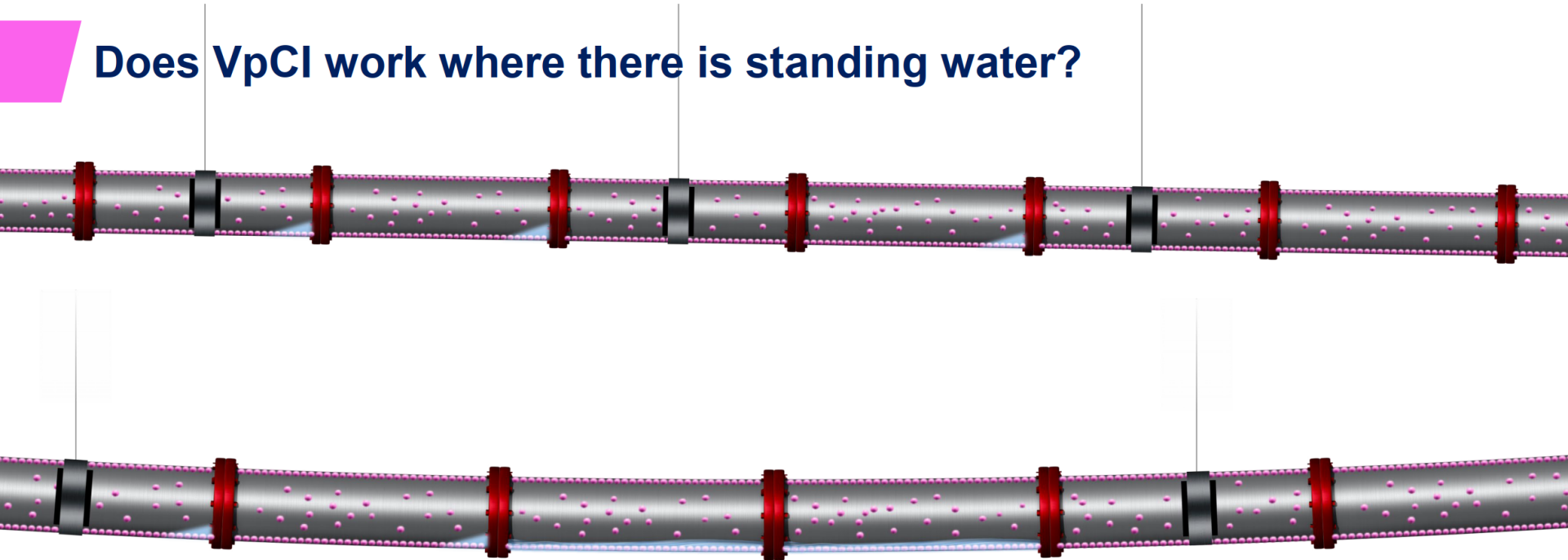

Yes, VpCI[®] molecules will penetrate standing water in the sprinkler system and protect the pipe beneath it. VpCI[®] molecules are water soluble which means that they easily dissolve in water due to their hydrophilic nature, making the exiting water a saturated VpCI solution.

VAPOR PIPE SHIELD™ & OIL-LESS AIR COMPRESSOR PACKAGE

FOR DRY & PRE-ACTION FIRE SPRINKLER SYSTEMS

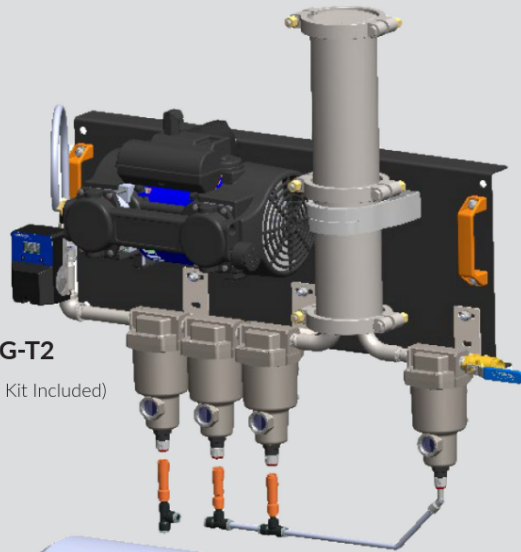

VPS-PKG-T2

(Tank Connection Kit Included)

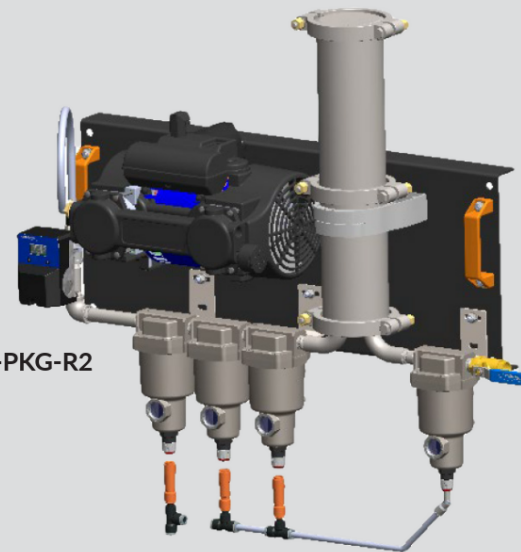

VPS-PKG-R2

CE | UK
CA



In the first 18 months available, Vapor Pipe Shield has had over five hundred successful installations in the U.S. & Canada.





Government

Vapor Pipe Shield is listed for use in all NSA facilities in the current version of their Facilities Criteria.

